

Section 5

Baffles	5,10, 14, 15, 31
Brackets.....	2, 6, 13
Clamps	14-16
Drag Pipes	3-7, 12
Exhaust Wrap	5
Hardware	13,34
Mufflers	2,4,6,9,11-25,27-28
Heat Shields	2, 10, 12, 23, 30-33

Cycle Shack

FLT, FLHS	20-30
FXDB, FXDC	7
FXR	6
FXST,FLST	2-3
Sportster, Evo 1986-on	8-11
Paughco	4, 7-9, 26-29
Samson	7
S&S.....	8, 20

FXST-FLST



Cycle Shack Muffler Pipes- PHD-140 Series

Cycle Shack's PHD-140 Series pipes feature true one-piece construction, accepts the original factory heat shield and has 1-3/4" head pipes and 2-1/2" diameter mufflers. Uses stock flange rings, gaskets, and hardware and will mount to the factory bracket. Fits 2000-06 FXST.

PCP Muffler Style

95231 Tapered

95233 Super slash



FXST, FLST Exhaust Support

Support mounts stock or custom drag pipes to frame. Stock on FXST but can be used on Fat Boy to mount lower drag pipes. PCP 82010 can be used on 1995-on models to mount early style Porkster or Cycle Shack drag pipes.

PCP Application

82010 FXST-FLST 1984-94 black (65459-84A)

82011 FXST-FLST 1984-94 chrome

82012 FX, FLST 1995-99, chrome (65459-95)

82013 FXSTF-N 1995-99, chrome (65515-95)

24043 Chrome bolt kit



FXST Tapered Chrome Slip-on Muffler Set

Tapered cone style mufflers to fit 2007-on FXST.

95610



Muffler/Drag Pipe Heat Shields

Designed to fit with either Drag or Muffler type pipes. Covers do not have cut out for cross-over tube. Sold in sets.

94020 Smooth Softtail 86-99

94021 Perforated Softtail 86-99

94024 Ribbed Softtail 86-99

94025 Smooth XL 1986-03

FXST Chrome Slip-on Muffler Set

Features chrome end tips. Fits 2007-on FXST.

94704



Stainless Steel Exhaust Taper Valves

27501 Evo (pair)



Preston's 2-1/4" Side Sweeper Exhaust Pipes

Pipes have oxygen sensor ports with plugs which can be removed for 2007-on models to install sensors. Order baffle rings separately. These pipes do not have the exhaust flanges for mounting, therefore the originals can be used.

95962 FXD-FXDWG 2006-on



Drag Pipes-Cycle Shack

These 38" long straight-through drag pipes fit the 1984-on FXST-FLST Softail®. Available in traditional 1-3/4" diameter or beefier 2" O.D. tubing. Front pipe mounts to factory support tube or use our BK-8 mount kit #27008 (not included) and rear pipe mounts to chrome fender strut. To be used with factory flange rings and gaskets.

95234 1-3/4" FXST Drag pipes 1984-06

95235 2" as above for 1984-06



Down Draft 2-1/4" Pipe Set Softail 1984-06

Looks great with #21813 turbo fan velocity stack, sold separately.

95311



Stainless Steel Taper Valve Exhaust Kit

This valve fits into the header at the flange area to compensate for exhaust velocity when large diameter pipes are installed. Fits Evo and XL models 1986-on with large O.D. aftermarket pipes. Kit includes 2 valves with gaskets. Fits Softail 84-on, FXD 91-on, FXR 84-94, XL 86-on

27502 Kit



6444 PHD-114GF, 1 3/4" Mini-Tail Muffler Pipes 1984-99

Shotgun Muffler Pipes-Cycle Shack

This is the look the 1984-99 Harley-Davidson FXST-FLST Softail was made for. This traditional rigid look is available with 1-3/4" O.D. head pipes with Mini-Tails mufflers. All feature our exclusive 16-gauge tubing, true one-piece construction, and show-chrome. Fits 1984-99 FXST-FLST Softails. (will not fit 1985-86 FX 4 speed models). Use our 1164 heat shield to keep boots and pants from melting all over the beautiful show-chrome. Front pipe mounts to factory support tube or to our BK-8 Mounting kit (not included, see below).

6444 Mini-Tail Mufflers 1984-99



Maxx-Shot Drag Pipe Set Softail 1984-06

Features 1-3/4" headers with full cover 2-1/4" form fit covers. Brackets & removable baffles included.

95984



Exhaust Gasket for Harley Evolutions

A woven wire mesh crush gasket for use with all Evolution motors when installing OEM or aftermarket exhaust systems. (OEM 65324-83A).

25172 Pair

FXST



Chrome Up Sweep Header Sets by Paughco

Pipes include brackets and will accept straight fishtail extensions or mufflers which must be purchased and mounted separately. 1-3/4" O.D.

PCP	Application
95988	1984-94 FXST
95989	1995-99 FXST



Evo Exhaust Flanges - Chromed

Fits 1983-on BT and replaces 65328-83.

- 27202** Complete kit (Softail 84-03, FLT 84-*, XL 86-01, FXR 84-94, FXD 91-05)
- 753** Flange and retainer kit (2 clamps, 2 retainers)
- 11105** Snap rings (65325-83) (10 Pack)
- 25172** Stainless woven gaskets (pr)
- 72188** Exhaust stud and nut kit (4 studs, 4 nuts)



Chrome Radii Curved Pipe Set

Features full curve with 2" OD for 1984-06 FXST models with Rigid or Softail frame. Bracket included. These pipes are steeped up from 1-3/4" at the header

PCP	Years
95955	1984-06



TC Exhaust Flanges for 2004-on

Late style exhaust flanges are designed to prevent warping.

71016 Pair

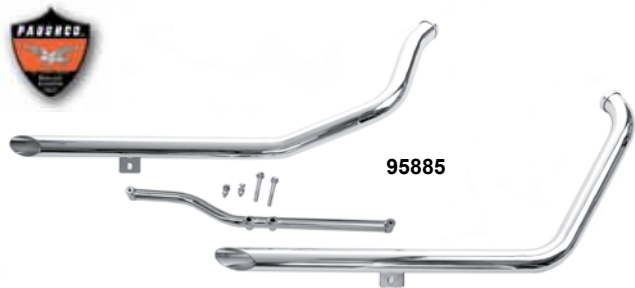

Cycle Shack Replacement Mufflers 1995-99

Light weight, 2 1/2" O.D. slip-fit replacement mufflers for 1995-99 FXST, FLST, FLSTF, and FLSTN "Fatboy" models; feature an all-steel core that will not burn out. 1995-99 models bolt to OEM bracket #65459-95.

Sold in pairs

PCP	Style	Description
94756	Turn-outs	FLSTF/N "Fatboy" 1995-99

Paughco 1-3/4" Drag Pipe Sets 84-99 Evo Softails

Fits all Softails with Evolution engines from 84-99, including FL Softails with floorboards. 40" Systems include mounting bracket to ease installation. Heat shields are recommended.

Chrome 40" Long Exhaust Systems

PCP	Item
95885	Slash cut
95907	Goose cut
75027	Front heat shield
75028	Rear heat shield
75029	Hanger bracket





FXST Short Stuff Pipe Set 1984-06

Features 1-3/4" chrome headers with full coverage 2-1/4" heat shield set.

95959



MCM FXST Drag Pipe Sets

Chrome pipes are 1-3/4" slash cut style 38" length and mount by stock brackets. Heat shields are included with PCP #95957 only.

95957 1984-99, with formed heat shields

95964 1984-06



High Temperature Exhaust Wrap Kits

- Reduces radiated exhaust heat.
- Handles 1200°F continuous; 2000°F intermittent.
- Accel kits include 4 extra-long stainless steel tie wraps

PCP	Accel	Width	Length	Colour
21681	28575	2"	25'	Black
28581	28576	2"	25'	Tan
21769	-	1.5"	25'	White
21795	-	1.5"	25'	Black
21603	28579	Stainless steel tie wraps (4 pk)		
21604	-	Stainless steel tie wraps (10 pk)		



Radii Monster Drag Pipes 1984-06

Feature 2-1/4" O.D. for 1984-06 FXST models. Order baffles & mount bracket separately.

PCP Style

95981 Down slash

82016 Mount bracket



Exhaust Gasket for Harley Evolutions

A woven wire mesh crush gasket for use with all Evolution motors when installing OEM or aftermarket exhaust systems. (OEM 65324-83A).

25172 Pair



2-1/4" Torque Tube Set

Will quiet loudness. 4-1/2" long for use in 2-1/4" straight pipes

73564

FXR-FXRT-FXLR Models



Cycle Shack Mufflers for FXR-FXRS-FXLR

Replacement mufflers for the 1982-86 FXR-FXRS-FXLR and the 1987-94 FXR-FXRS-FXLR models. These low restriction show-chrome beauties also offer improved performance. Includes hidden channel mounts and T-bolts for mounting to factory support tube. Uses stock clamps. **Sold as a set of 2.**

1982-86 FXR-FXRS

- 3534 Turn-Out Mufflers
- 3538 Baloney-Slice "SS" Mufflers

1987-94 FXR-FXRS

- 95715 Turn-Out Mufflers

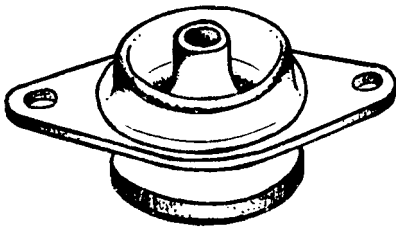

FXR Exhaust Bracket Mounting Block

Fits all FXR 1982-86 models. Replaces 65780-82. Each. 27242

1164



Heat Shield

This beautiful chrome 7" long leg protector will keep your passenger's boots and pants from melting on your exhaust pipes. Fits 1-1/2" to 2" O.D. pipes.

1164



Drag Pipes-Cycle Shack

2" O.D. 40" long straight-through pipes for drag racing. Fits 1984-94 Evolution engine rubber mount FXR, FXRS, FXRT, and FXLR models (including the 1986-on Low Rider® and Super Glide®). Includes channel mounts and hardware for mounting to factory brackets. Designed to be used with factory clamps, flange rings, and gaskets.

6437 2" Drag Pipes

FLSTF "Fat Boy"



Cycle Shack 1-3/4" Muller Pipes

Mini-Tails muller pipes are designed as a direct bolt-on replacement for the factory's original exhaust system on the FLSTF "Fat Boy" and Nostalgia models 1991-06. Accepts the original factory heat shields. Has 1-3/4" head pipes, 1-piece construction and chrome finish. These pipes eliminate the cross-over tube used on OEM factory pipes and bolt directly to the factory muller support bars on 1991-94. Order bracket BK-11 (Preston 27009) to mount 1995-later models. Reuse stock flange rings and mounting hardware.

95106 Mini-Tails Muller Pipes (PHD-128F)

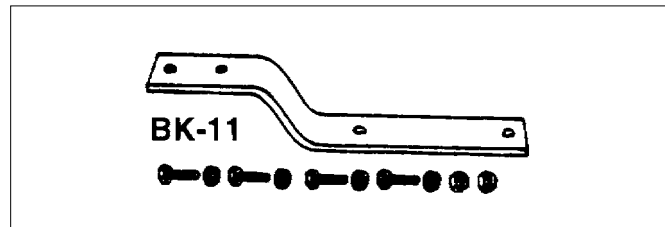

Mounting Bracket Kit

The BK-11 bracket kit is used for mounting the front pipe to 1995-later FLSTF/FLSTN models.

27009 BK-11

Samson



Dyna 1991-04 (except 2003-04 FXDWG)

PCP	Mfg#	Style
95975	D-206	Classic

FXD-FXDC-FXDWG



95880 Installed

Paughco 1-3/4" Exhaust Systems-Dyna Glides

Fits Twin Cam Dyna Glides with fuel injection and the large 2-pin oxygen sensors in the headpipes. Heat shields are recommended.

Chrome 40" Long Drag Pipe Set

Drag pipes attach to the OEM mounting brackets when you re-use your stock P-clamps. 08-on FXDF and 10-on FXDWG models require the additional purchase of a Paughco #75011 rear pipe mounting bracket and one each of OEM 65440-06 and OEM 65946-07 clamps to install.

PCP	Item
95880	Slash cut drag pipes 1991-11



95884

38" Long Muffler Sets 2006-11

Attach to the OEM mounting brackets when you re-use your stock P-clamps. 08-on FXDF and 10-on FXDWG models require the additional purchase of a #75011 rear pipe mounting bracket, a #75008 muffler support bracket and one each of OEM 65440-06 and OEM 65946-07 clamps to install.

PCP	Item
95883	Tapered
95884	Super Slash Cuts

Heat Shields and Mounting Brackets

PCP	Item
75009	Front heat shield
75010	Rear heat shield
75011	Custom rear pipe mounting bracket (65695-06, 65696-08)
75008	OEM style muffler support bracket



75008

Sportster



Paughco 9Twentyfives 2-1/4" Exhaust Systems for Evolution Sportsters

Mandrel bent pipe sets include mounting brackets and are available in chrome or satin black powder paint. Fits both mid-control and forward control models. 2004-on pipes are set up for oxygen sensors and include plugs if sensors are not used. Slip-in baffles with end caps are available as well as front and rear heat shield sets.

Chrome Short Cut Exhaust Systems

Chrome finish.

95908 86-03

95909 04-14

Long Cut Exhaust Systems

PCP Black Years

95910 95911 86-03

95912 95913 04-14

Slash Cut Exhaust Systems

PCP Black Years

95914 95915 86-03

Front and Rear Heat Shield Sets

PCP Black Years

75030 75031 86-03

75032 75033 04-14



Slip-in Baffles for 925 Pipe Sets

PCP Black Item

75035 75036 Tips for short cuts/long cuts (pair)

75034 Perforated baffle for all systems (each)

S&S Power Tune Sport Performance Exhaust

- Bold styling, authoritative rumble
- Dual pipes with hidden crossover for wide power band
- Increased torque & HP
- Built-in bungs for EFI oxygen sensors
- 2-1/2" diameter heat shields for 220° coverage
- Compatible with forward and mid controls
- Includes removable baffles, bung plugs & exhaust port gaskets

Chrome Heat Shields	Black Ceramic Heat Shields	Application
5500544	5500545	1986-15 FXST (except FXCW/C, FXD, FXSBSE)
5500542	5500543	2006-15 Dyna (except 12-15 FLD and 14-15 FXDL)
	5500231	2004-13 XL
5500379	5500380	2004-15 XL

Optional End Caps-Sold Separately

- Available in two styles and finishes
- Fits FXD, FXST, XL

Chrome	Black Ceramic	Style
5500229	5500228	Classic straight
5500209	5500208	Sculpted angled



Short Cut

Long Cut

Slash Cut



Paughco 1-3/4" Chrome Exhaust Systems For 86-03 Evolution Sportsters

Fits all rigid 883, 1100 and 1200 models through 2003 (not rubber-mounted engines). 38" Long with slider channel on front pipe. Includes a brake pedal stop and mounting bracket. Heat shields are recommended.

PCP	Item
95895	Megaphone
95884	Tapered
75025	Front heat shield
75021	Rear heat shield



Paughco 1-3/4" Upsweep Shotgun Exhaust Sets For 86-03 Rigid Frame Evolution Sportsters

Upsweep fishtail and headpipe sets will fit all 86-03 rigid Evolution Sportster engines (not rubber-mounted) when installed in Paughco rigid frames. Systems include hanger bracket kit. Combine the headpipe set with the additional purchase of fishtail or bell tip mufflers for a custom exhaust system. Heat shields are recommended.

Chrome Exhaust Systems

PCP	Item
95899	Complete upsweep fishtail exhaust system
95906	Upsweep headpipe sent only
75025	Front heat shield
75026	Rear heat shield

Mufflers

Sold each.

PCP	Length	Style
75022	22-1/2"	Fishtail
75023	20"	Bell tip
75024	22"	Bell tip



Paughco 1-3/4" Staggered Dual Pipe Sets For 86-03 Evolution Sportsters

Chrome 38" long drag pipe and muffer sets bolt to the stock HD mounting bracket for easy installation. Fits all rigid 883, 1100 and 1200 models through 2003 (not rubber-mounted engines). Includes a brake pedal stop/mounting bracket. Heat shields are recommended.

PCP	Item
95896	Super Slash cut
75025	Front heat shield
75021	Rear heat shield



95906 Installed with 75023

Sportster 1986-03



Cycle Shack XL Replacement Mufflers

Replacement mufflers for the 1980-03 Sportster models supplied with slip-fit staggered duals from the factory. Three styles of these low-restriction, show-chrome beauties to give your Sportster a new look and improved performance. Rear muffler mounts to factory support tube. Order brake pedal stop #2067. Uses stock clamps. Sold as a set of 2.

3526 Turn-Out Mufflers

3528 Tapered Mufflers



Preston's Sportster Slip-On Mufflers

Mufflers include removable baffle set. One bolt for quick removal. Install with stock header pipes.

94772 1980-03

94773 2004-13



1-3/4" Muffer Pipes-Cycle Shack

Cycle Shack's PHD-116F series muffer pipes for 1986-03 883cc, 1100cc, and 1200cc Evo Sportsters. Features 1-3/4" head pipes, 2-1/2" mufflers, chrome finish, all steel baffles, and 16 gauge one-piece construction. Brake pedal stop is incorporated into the front pipe mount. Uses stock flange rings, gaskets, and hardware and mounts to the factory bracket.

6221 Mini-tail style



2" Muffer Pipes

Same great styling and fit as our PHD-116T 1-3/4" pipes (above), but made with beefier 2" O.D. tubing. Fits 1986-03 883cc, 1100cc, and 1200cc Sportsters.

95224 Tapered

Torque Tube Set

Features improved baffling and back pressure for XL slash type mufflers with removable baffles. Use with slip-on mufflers with 3" inner diameter.

27362 V-Slots



Preston XL 1986-03 Chrome Covers

For Cycle Shack drag or muffer style pipes

94027 Set



Black Down Draft Drag Pipes

- 1-3/4" O.D. for rear application
- Includes bracket to connect two header pipes together
- Oxygen sensor bungs with caps, if required
- Order baffles and flange gaskets separately
- *Baffles may require cutting to desired length

PCP Application
95312 XL 2004-on



Down Slash Slip-on XL Muffler Set 2007-13

Chrome mufflers for Sportster with down slash ends. Features 13" removable baffles and cross tube nipples to connect to OEM bracket and installs to stock header pipe. Set of two.
95742



Black Slash Muffler Set XL 14-on

Slash-down mufflers with removable baffles and mounts using original hardware.
94712



XL Radii Curved Exhaust Headers

2" Diameter pipes for XL models 1986-07.

PCP Application
95996 1986-07 (no sensors)
27297 2004-07 bracket



Wyatt XL Side by Side Pipes 2004-on

Fits XL and XLC models with forward controls. Pipes are 1-3/4" at head and 2-1/4" at end and includes baffle set and bracket.

PCP	Type	Years
95995	Straight	2004-06
95999	Slash	2004-06
95971	Slash	2007-13

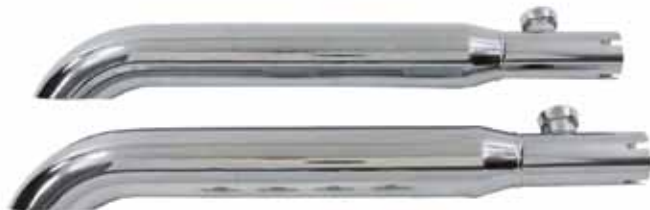

Chrome Turnout Slip-On Muffler Set

Dura chrome Superlow XL 883L muffler set mounts to existing bracket and includes baffles. Fits XL 07-13.

94709

Drag Pipes



All Cycle Shack Drag Pipes have slotted mounts on rear of pipe. Must use mount brackets on page 5-18. (Not supplied with Cycle Shack Drag Pipes)

Cycle Shack Pipes for Evolution Engines

1-3/4"	2"	Fitment	Length
	6437	1984-* FXR's ONLY	38"
95234	95235	2000-06 FXST, FLST	38"



Muffler/Drag Pipe Heat Shields

Designed to fit with either Drag or Muffler type pipes. Covers do not have cut out for cross-over tube. Sold in sets.

94020	Smooth Softail 1986-99
94021	Perforated Softail 1986-99
94024	Ribbed Softail 1986-99
94025	Smooth XL 1986-03



Preston Cycle's Own 1-3/4" FXST Shot Guns

These pipes require "P" clamps (included) for mounting.

Chrome Drag Pipes

PCP	Model	Mounting	Length
95310	1984-99	Stock Tab	40"



Billet End Tips

Fits 1-3/4" straight cut drags.

PCP	Finish
27137	Chrome
27138	Black



Evo Stainless Exhaust Taper Valve

27501 Pair



Kreem Blue Shield

Blue Shield is an internal exhaust pipe sealant that is designed to prevent 'pipe bluing' on properly tuned motors. Since bluing is caused by excessive heat, it may still occur if an engine is not in proper tune or if the carburetor is jetted too lean. Slight bluing may occur on pipes with extremely sharp bends coming from heads. Install on new, clean pipes only.

78008 Each

Mounting Hardware



FXST, FLST Exhaust Support

Support mounts stock or custom drag pipes to frame. Stock on FXST but can be used on Fat Boy to mount lower drag pipes. PCP #82010 can be used on 1995-on models to mount early style Porkster or Cycle Shack drag pipes.

PCP Application

- 82010** FXST, FLST 1984-94, black (65459-84A)
- 82011** As above, chrome
- 82012** FXST, FLST 1995-99, chrome (65459-95)
- 82013** FXSTF 1995-on, chrome (65515-95)
- 24043** Chrome bolt kit



1995-05 Dyna Chrome Exhaust Support

Replaces 65548-99
27364

Exhaust Cross Over Bracket 1995-08

27468 Touring 1995-08



Offset Bracket

For exhaust systems.
730

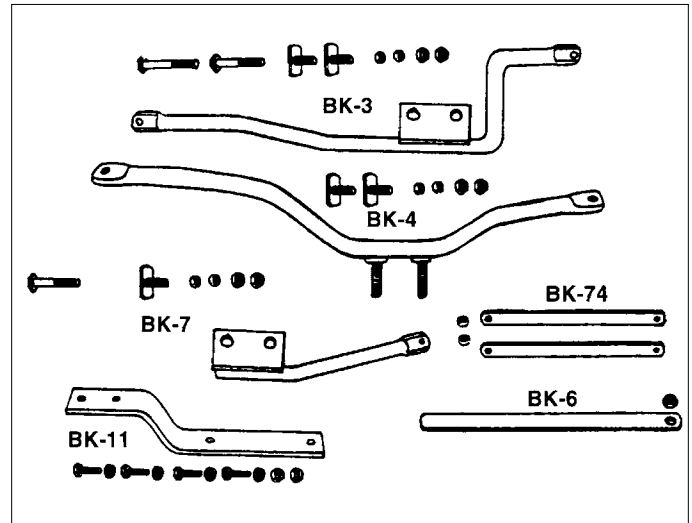

Cycle Shack Mounting Brackets

Supports are available to fit Cycle Shack's muffler and drag pipes. A universal strap bracket is also available to fit most other pipes. Black finish.

PCP Application

- 6651** FLH electric start only PHD-118 series (BK-3)
- 6652** XL PHD-112 and PHD-117 series mufflers and PHD-110 and PHD-210 drag pipes (BK-4)
- 27007** 12" Strap bracket for rear pipe on PHD-121 series muffler and PHD-111 and PHD-113 series Shotgun pipes (BK-6)
- 6654** Early FLH PHD-125 series pipes (BK-7)
- 27009** FLST 1995-04 PHD-128 and PHD-147 (BK-11)
- 732** Pair of 12" long universal strap brackets to fit other pipes for the H-D 74" engine produced with mounting studs. Not for use with adjustable channel mount. (BK-74)



T-Bolt Set

For use with muffler pipes that have channel type mounting. Includes nut.

797 5-16 x 18 bolt set (pair)



Exhaust Port Stud and Nut Kit

72188 For Evo and Twin Cam

Baffles & Clamps



Steel Pipe Baffle Set for 2" Diameter Pipes

Pipe baffles fit inside straight pipes. Baffles are 4" long and fit pipes with 2" diameter.
27344



Pipe Baffles (Pair)

Fits inside straight pipes, sold in pairs. Note: Baffle size denotes size of pipe into which it fits.

PCP	Size	Length
27360	1-3/4"	8"
27361	2"	8"
27537	2-1/4"	6"



3078



629



628



3768

Chrome Plated Pipe and Muffler Clamps

Sold each except where noted.

PCP	Size	PCP	Size
774	1-1/4"	629	1-7/8" (pair)
775	1-3/8"	3768	2"
627	1-1/2"		
776	1-5/8"		
628	1-3/4"		

Chrome Plated Muffler Hanger Clamps

Feature 4-1/2" long strap to mount muffler body to frame. Sold in pairs unless noted.

3075	1-7/8"
3076	2-1/2"
3077	2-3/4"
3066	2-7/8"
3078	3"
3080	3-1/2"

Short Strap as OEM Bracket

2549	2-7/8" Chrome (each)
3079	3-1/4" Chrome (pair)
3095	3-1/4" Stainless Steel (each)
94201	3-1/4" Chrome (each)



16203

Frame Mounting Clamp

1" Frame clamp for mounting exhaust pipes or foot pegs. Sold in pairs with hardware. Chrome plated.

16203



Chrome Smooth Clamps

Use these clamps to connect 1-7/8" O.D. mufflers to 1-3/4" head pipes. The edges are radiused and blend into pipes. Pinch clamp design with allen bolt for tight fit. Pairs.

16337

Baffles & Clamps



3317



831

Mini Pipe Baffles 4"

Short length, full performance, all steel baffles, sold each.

3317 1-3/4"

831 2"



Cycle Shack "SS" Muffler Pipe Baffle

Fits all "SS" style muffler pipes with 2-3/8" I.D.

3315 Sold Each



787

788

778

Chrome "P" Clamps

Clamps are made of cold rolled steel and are 1/8" thick and 7/8" wide. The adjustable flat bar of the clamps measures approximately 6-1/2". Sold each.

PCP Size I.D.

787 1-1/2"

788 1-3/4"

778 2"

59369 2-1/4" (pair)



3556

3557

12" Drag Pipe Baffles

These replacement drag pipe baffles are extra long, sold each.

3556 1-3/4"

3557 2"

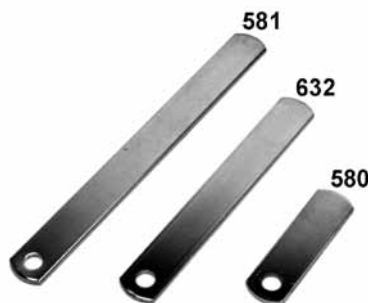

581

632

580

Chrome Universal Flat Straps

PCP Size

580 3" (each)

632 6" (each)

581 8" (pair)

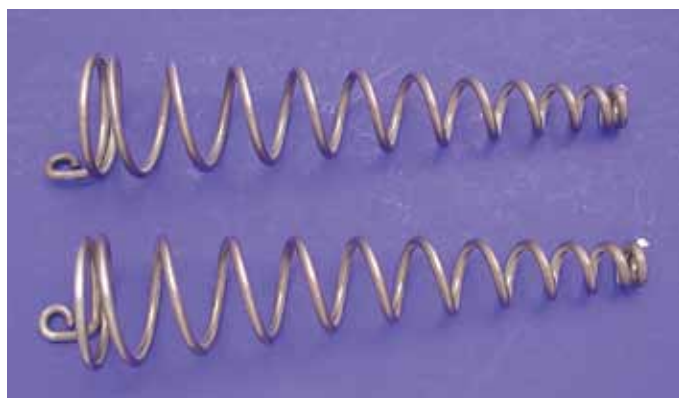

Power Spiral Baffles

Feature the latest designs in exhaust baffles. The minimum restrictive properties of the inverted cone allow for more power and yet still reduce decibel number to a more acceptable level.

8" 12" Size of Pipes

73635 73679 2"

73680 2-1/4"



94202

94203

94204

Chrome Centre Hangar Clamps for Mufflers

Clamps fit muffler OD sizes as noted. Sold in pairs.

Mounting tabs must be drilled.

PCP OD Size

94202 3"

94203 3 1/4"

94204 3 1/2"

Mufflers



Custom Black Slip-On Muffler Set

Black 16-1/2" long tapered muffler set with an inner diameter of 1-3/4". Features channel mounts, removable baffles, chrome end clamp set and chrome undrilled mount strap.

95725



Chrome Tapered Slip-on Muffler Set

Custom slip on mufflers measure 16.5" long and are 2.25" in diameter. Mufflers have channel mounts and welded-in baffles. Order inlet clamps separately. Pair.

94703



95740



Chrome Slip-on Muffler Sets XL 2007-13

3" outer diameter, features cross tube nipples to connect to OEM bracket. Includes baffles

PCP End Caps

95740 Chrome tapered ends

Chrome Billet Scalloped Pipe Ends

For 2-1/4" straight pipes. Sold in pairs.

59251



3487

16229



16283

23018



Shown Assembled

Chrome Clamps for Late 1985-94

Chrome steel muffler clamp is an updated version replacing 65722-85. Fits all late 1985-94 FLT/C, FLHT/C.

16261 Each

FLT Muffler Clamps

Choose body or inlet clamps for 1980-up when installing custom mufflers, sold in pairs.

PCP	Item	Finish	Year
3487	Wide type	Chrome	1985-94
16229	3" I.D. Body clamp	Chrome	1985-on
23018	Rubber mount	Black	1985-on (65724-85)
16283	Clamp	Chrome	1995-08 (65296-95A)

Chrome Frame Clamp

Fits frame for exhaust bracket mounting. Each.

PCP Size
73569 1"



Fishtails & Tips



Fishtail Tips

Chrome exhaust tips slip over the outlet of the muffler or straight pipe. Available in 1-3/4" inlet diameter, these classic fishtail tips measure 7" long and 5-5/8" high. (Sold each).

3774 Fishtail 1-3/4" dia. x 7" Length - Fits 1-3/4" Pipe

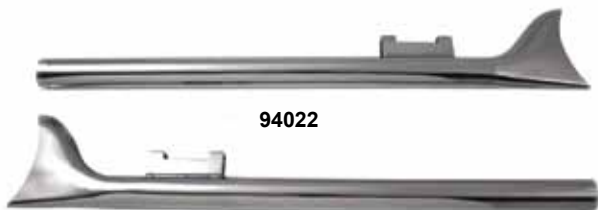

Unbaffled Fishtail Straight Pipes

94005 30" FLT 1985-94 w. welded brackets (pair)

94006 30" FLT 1995-16 (pair)

94022 30" FLT 1995-16 with channel brackets (pair)



Fishtail Mufflers - Chrome

2-3/4" diameter with inlet to fit 1-3/4" O.D. pipes. Steel baffle core. Clamps sold separately.

6351 30" long (each)

6352 36" long (each)

95751 31" 1985-94 FLT (pair)

3077 Body clamps (pair)

629 End clamps (pair)

16261 FLT End clamps (pair)

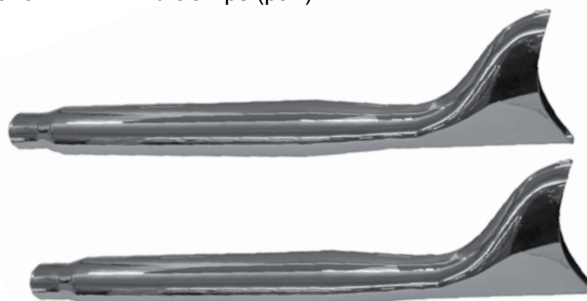

Chrome Tapered 27" Fishtail Muffler

Features 1-3/4" inlet. Uses 2-1/2" body clamps, sold separately, for mounting.

95752 Pair



Chrome 30" Straight Pipe Extension

Has 1-7/8" I.D. to fit over 1-3/4" pipes. Allows extension to slide over to desired length. Pair.

94007



Classic Fishtail Muffler

Chrome muffler with an antique style tip. This clean, bracket-less muffler allows left or right side mounting and has a 1-3/4" inlet. 34" long with 2-1/2" body O.D.

6507

Mufflers



94768

Chrome Universal Turnout Mufflers

Mufflers have a 1-3/4" I.D. inlet and feature a channel type mount track on the rear of the pipe.

PCP	Length	Outside Diameter
94770	19.5"	2-1/2" (each)
94768	20"	2-1/2" (pair)



1-3/4" Slip-on Muffler (19")

Chrome muffler features megaphone styling with remable baffles and universal mount bracket included.

94769 Each



94772



Slash Down Muffler

Features removable baffles which can be modified for alternate tuning characteristics. Mufflers bolt to original bracket on 1995-on FLT touring models. 32"L with 3.5" O.D.

PCP	Fits
95772	2009-on



94773

XL Slip-On Muffler Sets with Removable Baffle

RMB Style mufflers include removable baffle set. One bolt for quick removal. OAL 18", ID 1-3/4", OD 2-1/2".

94772	1980-03
94773	2004-13
16283	RMB style clamps for above



94775

94776

Scalloped Fishtails

Chrome mufflers have a 1-3/4" inlet and offered with 2 body sizes. Includes end clamp. (sold each)

PCP	Length	Muffler O.D.
94775	30"	2-7/8"
94776	22"	2-1/2"

Mufflers



Cycle Shack Replacement Mufflers 1995-99

Light weight, 2 1/2" O.D. slip-fit replacement mufflers for 1995-99 FXST, FLST, FLSTF, and FLSTN "Fatboy" models; feature an all-steel core that will not burn out. 1995-99 models bolt to OEM bracket #65459-95.

Sold in pairs

PCP	Style	Description
94756	Turn-outs	FLSTF/N "Fatboy" 1995-99

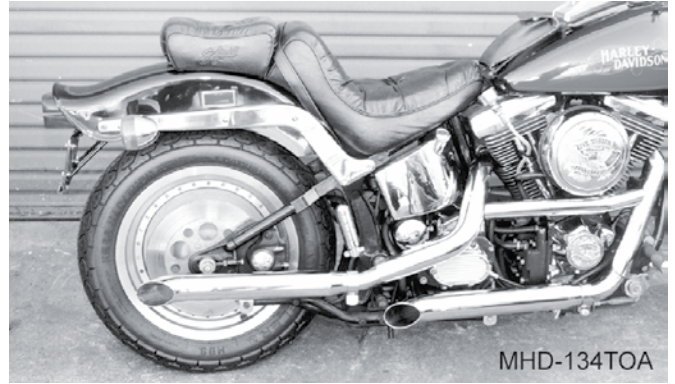

Cycle Shack Mufflers for FXE and FXST-FLST

Replacement mufflers for the 1980-85 FX-FXE-FXS-FXEF-FXB-FXWG and 1984-94 FXST-FLST Softail® models and the new FLSTF Fat Boy® with staggered dual muffler pipes. Features include lighter weight, 2-1/2" O.D. muffler with an all-steel core that will not burn out. Mount tabs bolt directly to the factory pipe bracket. Uses stock clamps.

Sold as a set of 2.

3520	Turn-Out Mufflers (MHD-134TO)	1984-94
3524	Baloney-Slice "SS" Mufflers (MHD-134SA)	1984-94



Retro 1970's Style Slip-on Tapered Muffler Set

Tapered muffler set with fluted design with 2" removable baffles. Fits XL 04-13. Some applications will require drilling a 1/4" hole into the header pipe.

94710	Dura-chrome
94711	Black

Tapered Muffler Set

Tapered muffler set with slotted track, chrome end clamps and strap mounting. For all models with 1-3/4" pipes.

PCP	Description
94705	Black
94706	Chrome

Replacement Slip On Mufflers

Low restriction mufflers are available in Tapered, 'SS' or Turnout styles and feature easy installation to factory support and head pipes. Pairs. 2000-06 FXST shown.

Tapered



SS



Turn-out



FXST, FLST FLSTF	FXR, FXRS, FXLR	FLSTF, N 1995-99	ALL XL 1980-03
1984-94	1982-86	94756	3528
FX, FXE, FXS, FXWG	3538	Turnout	Tapered
1980-85	SS		3526
3524	Turnout		Turnout
3520			
Turnout			

FXR, FXRS, FXLR,	FLSTF, FXSTD 2000-06
FXRT 1987-94	94766
95715	Tapered
Turnout	

FLT-FLHR 1985-later



1-3/4" Muffer Pipes-Cycle Shack 1985-94

These staggered duals for 1985-94 FLT-FLHS-FLHTC, and FLHR models with rubber mount Evolution® engines are available in 2 muffer styles, "SS", and turn-down. Each features Cycle Shack's all-steel baffle that will not burn out and get louder. Rear pipe mounts to original factory hanger located under luggage. Frame mounting hardware for front pipe is included.

95103 Turn-Down muffer pipes (PHD-126TD)

Note*** These pipes do not fit models with oil tank under the transmission.



Wide Oval Mufflers FLT 1995-16 (27 1/4" long)

Oval shape mufflers measure 2.5" by 5" Baffles are included. End clamps must be purchased separately.

95758



FLT Muffer Gasket 1985-on

25226 65721-92



S&S SPO Touring Mufflers 1995-16

These sculpted alloy, double-walled mufflers are mellow when you want them to be but offer a throaty big-block rumble when you get on the throttle. Offers significant torque gains in the mid range and are a great choice for long-distance and two-up riding. Fits 1995-2016 Touring models with non-catalyst mufflers. (Except 2010 Road Glide Custom, Street Glide and all Tri Glide models) Features visible machined-in S&S logo.

PCP Style

5500246 Chrome with black Xylan coated end caps

5500001 Chrome with chrome end caps

5500146 Jet-Hot black ceramic finish with chrome end caps

Touring Mufflers



95703



95705



95757



95717

95712

Touring Muffler Sets for 1995-16 FLT

Features 3.5" body diameter.

PCP End Caps

- 95703 Black long gun barrel tips
- 95719 Black removable gun barrel tip
- 95705 Black short six screw tips
- 95717 Black removable long tapered tip
- 95712 Shooter style end types
- 95757 Shark end cap

Chrome 3" Cone End Muffler Set for FLT 95-16

Chrome 28-5/8" one piece bullet muffler features a non-removable baffle with 3" diameter.

- 95714 Pair
- 95713 Each



Chrome Muffler Set for 1995-16 FLT

4" O.D. pipes feature removable cone style end caps. 95720

Muffler Bracket Cover Set

Fits 4" outside diameter muffler on Touring models. 44030



17305

Namz Oxygen Enrichment Device

Recommended for bikes with high flow air cleaners and performance exhaust systems. Reduce engine operating temperature between 20-30°. Just simply plug this in between oxygen sensor and wiring harness. Pair.

PCP Application

- 17305 2007-08 FLT, 2007-11 FLST, FXST models with Stage 1 kit installed. Works with stock ECM.
- 17306 2010-on FLT, 2012-on FLST, FXST models with Stage 1 or Stage 2 kit installed. Works with stock ECM.
- 17307 2007-on XL

Mufflers



FLT 2 3/8" Dumper Straight Pipe Sets

Fits FLT models and includes removable baffles. End clamps are sold separately.

PCP Description

- 95728** Pipe set 1985-94 28" long with hangar bracket
- 95727** Pipe set 1995-16 28" long with channel bracket
- 27365** Baffle set 1985-on
- 16261** End clamp 1985-94
- 628** End clamp 1995-on



Radii Slip-On Muffler Sets for FXD-FXDWG

Include removable baffle set with one bolt for a quick 30 second removal. Install with stock header pipes. Mufflers a fit 1995-05 FXD-FXDWG models. Muffler body is 3-1/4" O.D.

PCP Years

- 95708** 1995-06
- 16283** Clamp set

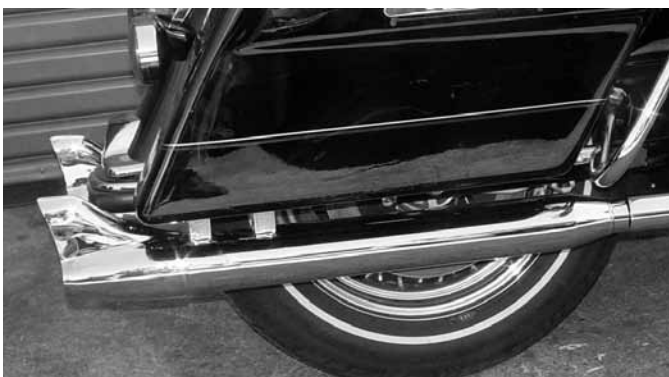

Cycle Shack Fishtail Rocket Tip Muffler (each)

29" Chrome muffler with fishtail rocket tip.

- 95716** Touring 1985-94



Touring Chrome Muffler Set for 1995-16 FLT

With removable end caps and has a 3.5" outer diameter.

- 95756**

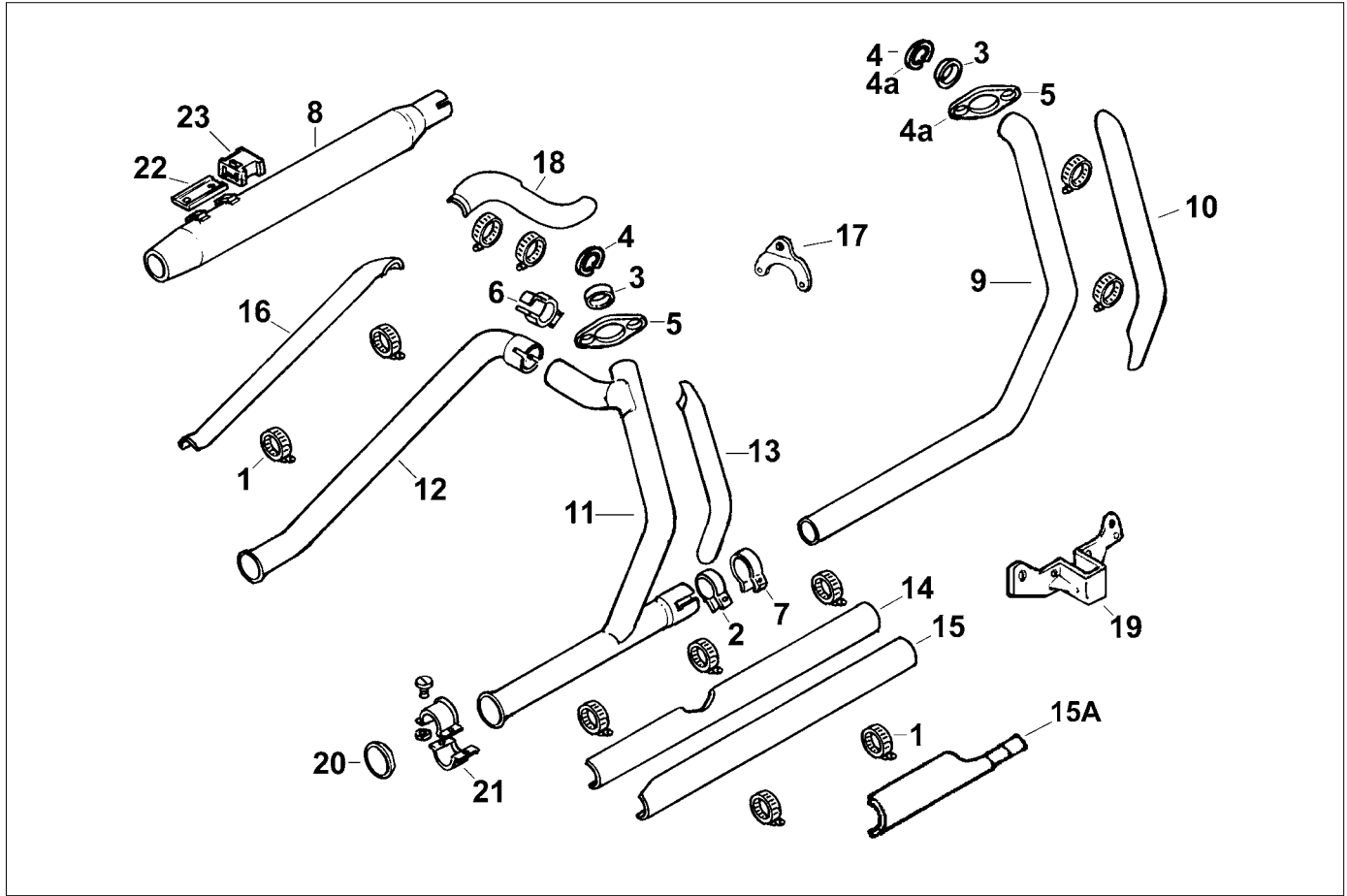

FLT Touring Dual Exhaust L1985-08 (USA)

Note specific year fitment

#	PCP	OEM	Description	#	PCP	OEM	Description	
1	16281	9955	Clamp, shield 1984-on (ea)	13	45937	65632-83B	Shield, rear exh/pipe 1984-97	
2	16282	65276-62	Exhaust clamp 1984-94 (ea)		45567	65951-98A	Shield, rear exh/pipe 1998-08	
	16283	65296-95A	Exhaust clamp 1995-on (ea)	14	94010	65634-81C	Shield, right exh/pipe 1981-91	
3	79467	65324-83A	Gasket, exhaust port 84-91 (10 pk)	15	45149	65634-92A	Shield, right exh/pipe 1992-97	
	79468	65324-83-A	Gasket, exhaust 1992-08 (5 pk)		45568	65634-98A	Shield, right exh/pipe 1998-08	
4	11105	65325-83A	Snap ring, exh/gask. 84-on (10 pk)	15A	45936	65611-92	Shield, right exhaust (rear) 92-94	
4a	753		Exhaust flange kit (4 pcs)		45211	65611-95	Shield, right exhaust (rear) 95-97	
5	16284	65328-83	Clamp, exh/manifold 1984-on (ea)		45569	65952-98A	Shield, right exhaust (rear) 98-08	
6	N/A	65502-89	Clamp, left exhaust pipe 89-94 ea	16	45216	65636-85	Shield, L/S rear exh/pipe 1985-94	
	16283	65283-94	Muffler clamp 1995-06 (ea)		45158	65636-95	Shield, L/S rear exh/pipe 1995-98	
7	16287	65519-52C	Clamp, pipe to bracket 86-06 (ea)		45570	65636-99	Shield, L/S rear exh/pipe 1999-06	
	16342	65654-97	Clamp, exhaust pipe 2007-08	17	16289	65645-89	Bracket, left rear exh/pipe 1989-94	
8	N/A	65538-95	Muffler, left 1995-03	18	45159	65647-83	Shield, left top exhaust pipe 83-98	
	N/A	65539-95	Muffler, right 1995-03		45575	65636-07	Shield, left rear exh. pipe 2007-08	
9	N/A	65621-83	Exhaust pipe, right front 1984-97	19	16290	65678-85D	Bracket, right rear exh/pipe 85-06	
	95753	65621-99A	Exhaust pipe, right front 1999-06		16344	65988-07A	Brkt, exh. mnt. at starter 2007-08	
	95759	65621-07	Exhaust pipe, right front 2007-08	20	79469	65721-85	Gask., muffler clamp L85-94 (10)	
10	45147	65630-83B	Shield, front exh/pipe 1984-08	21	16283	65296-95A	Muffler clamp 1995-08 (ea)	
11	N/A	65626-85A	Exhaust pipe, right rear 1985-94	22	16291	65723-85	Mounting bracket L1985-on (ea)	
12	95762	65627-95A	Exhaust pipe, left 1995-98		-	14602	27714-06	Seal ring 2007-09 (10 pack)
	95755	65627-99A	Exhaust pipe, left 1999-06		-	29145	27719-07	Oxygen sensor 2007-09 (ea)
	95761	65627-07	Exhaust pipe, left 2007-08					



Muffer Joint Gasket

Fits FLT 1985-94 and replaces 65721-85.

25226 5 pack

Mufflers



Cycle Shack 4" O.D. Touring Mufflers

Get a performance increase on FL, FLH, FLHR, FLHS, FLHX, FLHT Touring models from 1995-10 and will work with Cycle Shack's 2" head pipes (PHD-221, Preston #95863 and PHD-259, Preston #95862). Feature performance baffles and offer a deep throaty note that is mellow while cruising.

PCP Type for 2" head pipes

95798 SS (MHD 484SS)



95708

Tapered Muffler Set FLT 1995-on

Black tapered mufflers with cone shaped end caps.

PCP End Cap

94707 Black

94708 Chrome



FLT Radii Muffler Set with Chrome End Caps

Chrome muffler set has 3-1/2" outer diameter, removable baffle inserts, welded top mounts, formed inlet tubes and chrome end caps. Order bolts separately. Fits 95-on FLT.

95748

Cycle Shack 3" O.D. Touring Mufflers 1985-94

2 Piece end cap replacement mufflers are designed to fit the 1985-94 FLT, FLHT, FLHT/C, FLHR Dresser models with Evo motors. Fits OE crossover "Y" pipe and bolts directly to OE saddlebag frame hangers. MHD-289/290 series mufflers are designed to fit 1985-94 models with OE flared end head pipes and OE coupler clamps. Sold in pairs. Clamps not included.

MHD-289 Series feature a woven stainless steel wool sound blanket around the baffle that cancels the sharp crackle in the exhaust note. The tone is till deep and throaty, but the baffle allows you to hear your stereo

PCP Fits Woven Stainless Wool Baffle

95775 1985-94 SS (MHD-289SSA)

95777 1985-94 Slash down (MHD-289SD)

95779 1985-94 Rocket tip fishtail (MHD-289RA)

MHD-291 Series feature an all steel performance baffle.

PCP Fits All Steel Performance Baffle

95780 1985-94 Rocket tip fishtail (MHD-290RA)

Cycle Shack 3" O.D. Touring Mufflers 1995-on

2 Piece end cap replacement mufflers are designed to fit the 1995-on FLT, FLHT, FLHT/C, FLHR Dresser models with Evo and Twin Cam motors. Fits OE crossover "Y" pipe and bolts directly to OE saddlebag frame hangers. Sold in pairs. Clamps not included.

MHD-291 Series

One piece mufflers feature an all steel performance baffle.

PCP Fits All Steel Performance Baffle

95783 1995-on SS (MHD-291SSA)

95785 1995-on Slash down (MHD-291SD)

MHD-292 Series feature a woven stainless steel wool sound blanket around the baffle that cancels the sharp crackle in the exhaust note. The tone is till deep and throaty, but the baffle allows you to hear your stereo and works better with EFI TC-88 motors.

PCP Fits Woven Stainless Wool Baffle

95784 1995-on SS (MHD-292SSA)

95790 1995-on Turn out/down (MHD-292TOA)



Chrome 2 into 1 Exhaust Pipe Header Kit

- Looks like hot rod side exhausts
- 2" Header pipes with 11" outlet & 18mm oxygen sensor bungs
- Includes heat shield and hardware
- Accepts 12mm oxygen sensor unit, or can be plugged
- Will not work with floorboards
- Fits 1986-on FXST and 1991-on FXDWG

95972



**NEW ITEM
COMING SOON**

FLT Exhaust Header Pipes

PCP Front Header Pipes

95736 2010-16 FLT, FLHT, accepts 12mm O2 sensors

95734 1995-06, will require oxygen sensor plugs (chrome)

PCP Rear Header Pipes

95726 2009-16 FLT (chrome)



Black 2 into 1 Exhaust Header Set

- Includes front & rear header, turn-out ends & baffles
- Welded with black covers
- Remapping is recommended to reduce possible damage
- Fits 2007-16 FLT

95873



Chrome Tru-Dual Exhaust Set FLT 2010-16

- Independent exhaust pipes for each cylinder
- Includes chrome full length heat shields
- Has 12 mm oxygen sensor bungs
- Allows use of OEM mufflers

95872



Cycle Shack 2" Mufflers Touring 1995-08

The MHD-324 series mufflers feature a high-flow 2" O.D. stainless steel sound blanket baffle so you can hear your stereo. For 2" O.D. head pipes.

PCP 2" Mufflers with Stainless Steel Blanket Baffle

95792 Slash down (MHD-324SD)

95794 SS (MHD-324SS)

95796 Straight (MHD-324ST)

True Dual Exhaust

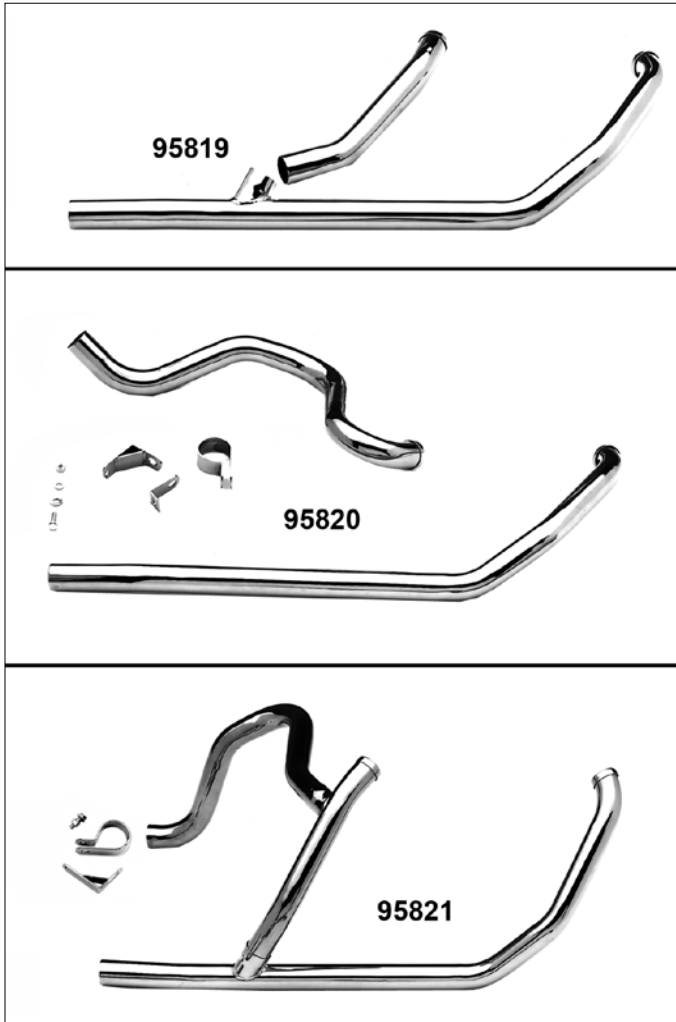

Cycle Shack 2" Dresser Duallies for Touring Models 2009-on

True dual, 2-into-1 separate head pipes replace the OE 2-1 header on 2009-on FLH, FLHR, FLT, FLHX models to help relieve excess heat under the riders right leg. Full 2" O.D. stepped head pipes provide increased flow and performance on mototrs over 100 c.i. Reuses OE heat shields on head pipes and is supplied with lower heat shield and left side crossover heat shield. Should be used with MHD-484, MHD-320 or MHD-324 series Cycle Shack mufflers with 2" O.D. baffles.

95862 (PHD-259)

Paughco 1-3/4" 2007-08 Touring Exhaust Systems

Head pipe sets fit 2007 FLT, FLHT and Road King models. Heat shields are recommended.

- | PCP | Item |
|--------------|---|
| 95819 | 2-into-1 head pipes only |
| 95820 | Independent dual head pipes only with a crossover bracket |
| 95821 | Crossover dual head pipes only with a crossover bracket |

Heat Shields

- | | |
|--------------|---|
| 94052 | Front heat shield |
| 94029 | Low front shield with notch for #95819 and #95821 |
| 94053 | Low front shield without notch for #95820 |
| 94054 | Rear shield for #95819 |
| 94055 | Rear shield for #95821 |
| 94056 | Crossover shield for #95820, #95821 |
| 94057 | Snail shield for right side rear cylinder on #95820 |



Oxygen Sensor Plug

Fits exhaust F/R fitting on 2004-09 FLT-FXD-Softail.

- | PCP | Item |
|--------------|-------------|
| 73734 | Plug (pair) |
| 29145 | Sensor (ea) |



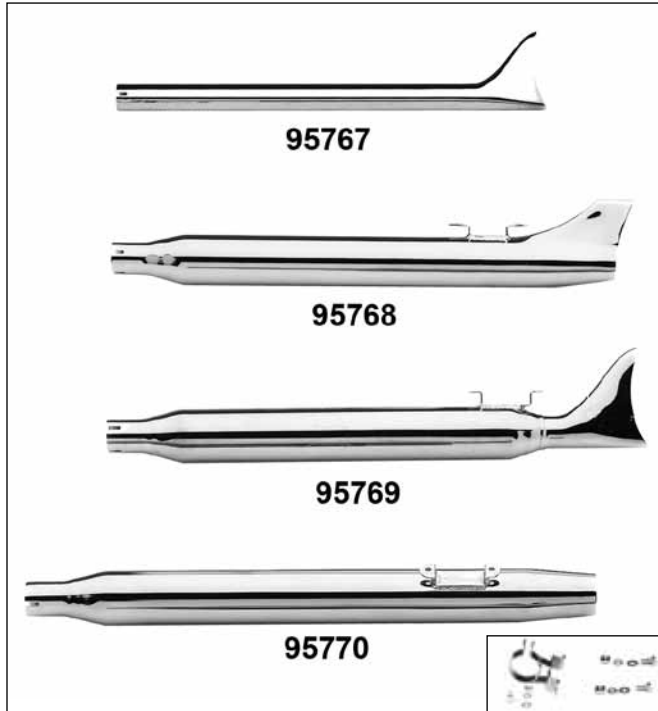

Paughco Touring Mufflers 1995-12

Extensions and mufflers are intended for use on 1995-12 Touring models. All measurements listed are overall length. Sold each.

1-7/8" Diameter Straight Fishtails

PCP	Length	Type
95767	31"	Fishtail
16346		Hanger clamp

3" Diameter Mufflers

Require no additional brackets for installation. Sold each.

PCP	Length	Type
95768	31"	Rocket
95769	31"	Fishtail
95770	30"	Tapered



Paughco 1-3/4" 2-into-1 Header Pipe Set

Chrome header pipe set only. Includes angle bracket for mounting front pipe. Fits TC Softails 2000-06. (733C8)

95813

Hanger bracket for tail pipe extension must be manufactured.

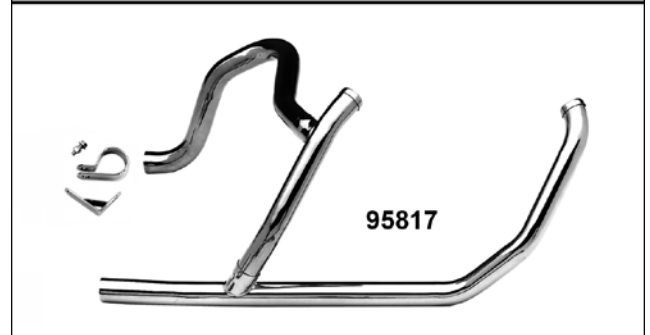
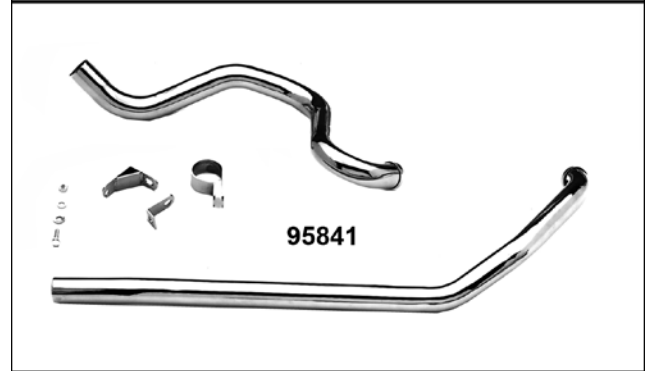
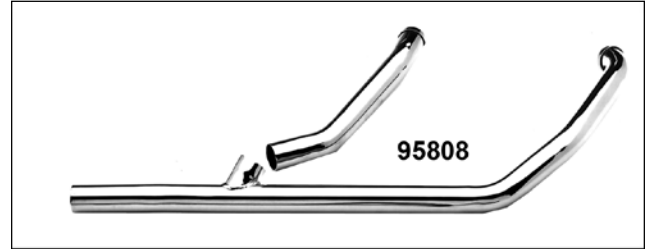

Paughco 1-3/4" Touring Exhaust 1995-2006

Head pipe sets fit 1995-2006 FLT, FLHT, FLHS and Road King models. Heat shields are recommended.

PCP Item

- 95808 2-into-1 head pipes only
- 95841 1995-98 Independent dual head pipes only with a crossover bracket
- 95856 1999-06 Independent dual head pipes only with a crossover bracket
- 95817 Crossover dual head pipes only with crossover bracket

Heat Shields

- 94052 Front heat shield
- 94029 Low front shield with notch for #95808 and #95817
- 94053 Low front shield without notch for #95841 and #95856
- 94054 Rear shield for #95808
- 94055 Rear shield for #95817
- 94056 Crossover shield for #95841, #95856 and #95817
- 94057 Snail shield for right side rear cylinder on #95841 and #95856



Oxygen Sensor Reducer Plug Set

Allow the use of late type 12mm oxygen sensors in earlier exhaust pipes with 18mm sensor bungs.

17319

Touring

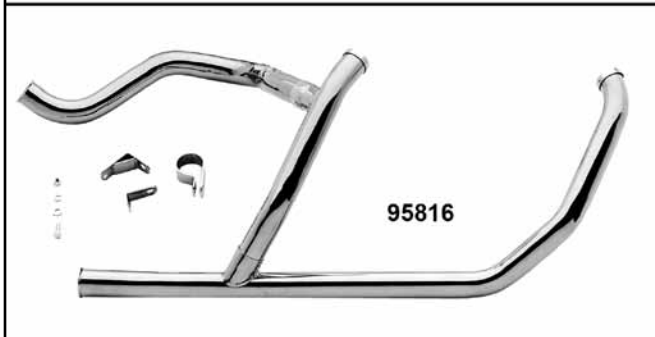
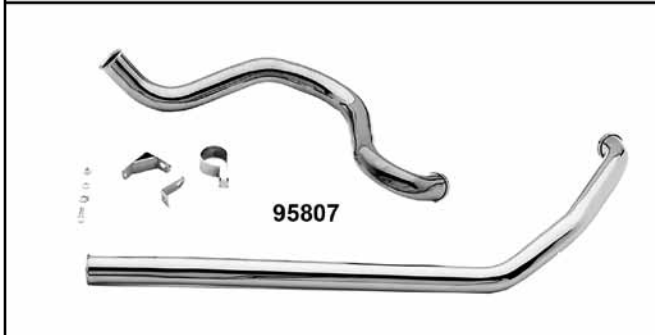
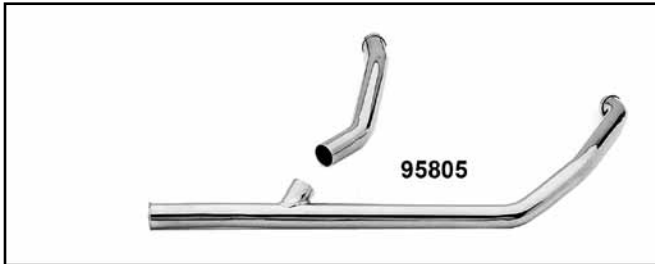

Paughco 1-3/4" Touring Exhaust L1985-94

Head pipe sets will fit all L1985-94 Evolution FLT, FLHT and FLHS and Road King models. Heat shields are highly recommended.

PCP	Item
95805	2-into-1 headpipes only
95807	Independent dual headpipes with crossover bracket
95816	Crossover dual headpipes with crossover bracket

Heat Shields

94052	Front heat shield
94054	Rear shield for #95805
94055	Rear shield for #95816
94056	Crossover shield for #95807 and #95816
94057	Snail shield for right side rear cylinder on #95807



Dual Cross Over FLT Exhaust Systems

Touring exhaust system includes headers heat shields, brackets and slash down mufflers with removable baffles.

PCP	Year
95864	1995-06
95865	2007-08
95866	2009
95867	2010-16



Paughco Rocket Mufflers Touring L1985-94

No additional brackets required for installation. 3" Diameter rocket muffler measures 31" long.

95763	Rocket muffler (each)
16345	V-clamp for late 1985-94

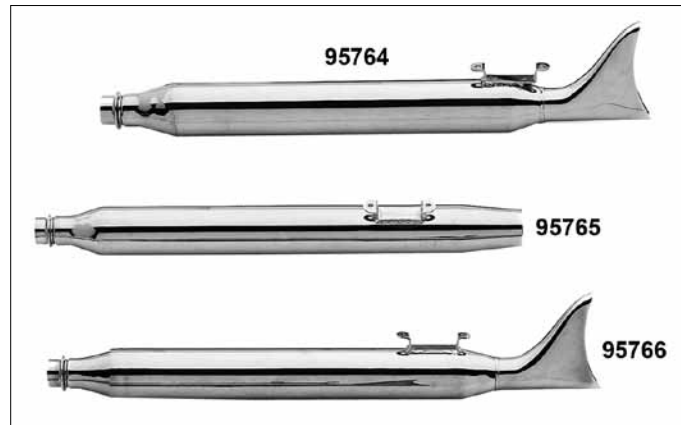

Paughco Touring Mufflers 1985-94

3" Diameter mufflers are intended for use on late 1985-94 Touring models and bolt right on with no additional brackets required. All measurements listed are overall length. Sold each.

PCP	Length	Type
95764	29"	Fishtail
95765	29"	Tapered
95766	31"	Fishtail
16345		V-Clamp



True Dual Exhaust



95859



95844

Radii True Dual Kit for Touring Models

Includes chrome true dual crossover kit with clamps and wide oval muffler set.

PCP	Item
95858	1995-06
95859	2007-08
95850	2009 only

True Dual Chrome Exhaust Systems-Paughco

These systems feature a single pipe for each side. Each pipe is independent, rear pipe for the left and front pipe for the right without intersection. 1-3/4" O.D. Order 2 piece heat shield set separately. ****Note These #'s are Preston's version**

PCP	Application	Heat Shield
95841	1985-98 FLT	94044
95856	1999-06 FLT	94044
95842	1986-94 FXST-FLST	94045
95843**	1995-99 FXST-FLST	94045
95919	1995-99 FXST-FLST	94045
95844	2000-06 FXST-FLST	94045
95845**	2000-06 FXST-FLST	



95805



Stock Type 2 into 1 - Chrome Pipes

1984 Evolution type fits FXST 1985-99 and FLST 1986-99 when early FL look is desired.

95802	1984-99 FXST-FLST
45562	Chrome rear heat shield for #95802
95803	1984-94 FXR-FXRS
95805	1985-99 Evo FLT

VT True Dual Cross Over Header

Fits FLT, FLHT, FLHR, FLTR. Heat shields, clamps, and hardware are included. Order 1995-06 type muffler separately.

PCP	Item
95852	1995-06 Header pipes (no O.S. bungs)
95857	2007-08 Header pipes
95851	2009 Header pipes
95848	2010-16 Header pipes

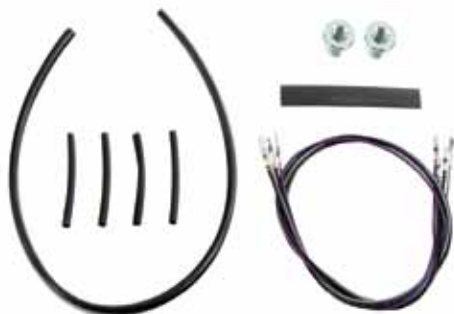

Oxygen Sensor Harness

For 2009 FLH models with header set. Complete with front extension harness and a pair of reducing bungs. Bungs have an 18mm O.D. and a 12mm I.D.

28799



95851

Dual Exhaust



Chrome Dual Pipe Cross Over Systems-EVO

Less Mufflers and Shields		Heat Shield
95814	FXST-FLST 1984-99	94037
95818	FXST-FLST 2000-06	
95816	FLT 1985-94	94039
95817	FLT 1995-06	94040



Chrome Dual Crossover Headers by Run Roder for 1984-99 FXST-FLST

Includes 2 heavy duty muffler mounting brackets. Uses stock exhaust pipe and retainers and can install any 1-3/4" muffler pipe on the system. **Note:** Installation of left side muffler mounting bracket requires drilling and tapping of lower frame boss.

95814 1995-99

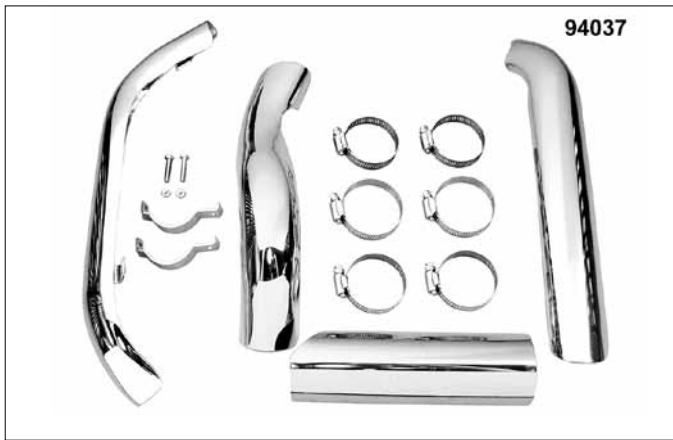

Chrome Universal Heat Shields

Stylish shield feature a groove or flame design.

Groove	Flame	Size
59695	-	4"
-	59699	6"



FLT Extended Front Exhaust Heat Shield

Covers the exposed exhaust pipe adjacent to rider footboard. Mounts with existing hardware. (65694-05)

59702 1983-99 FLT and 2002-08 FLHTCUI

Maltese Chrome Heat Shield

45157 9" Long



Chrome Skulls Heat Shield

45162 9" Long





Billet Pipe Ends for 2.25" Straight Pipes

PCP Finish
21682 Chrome

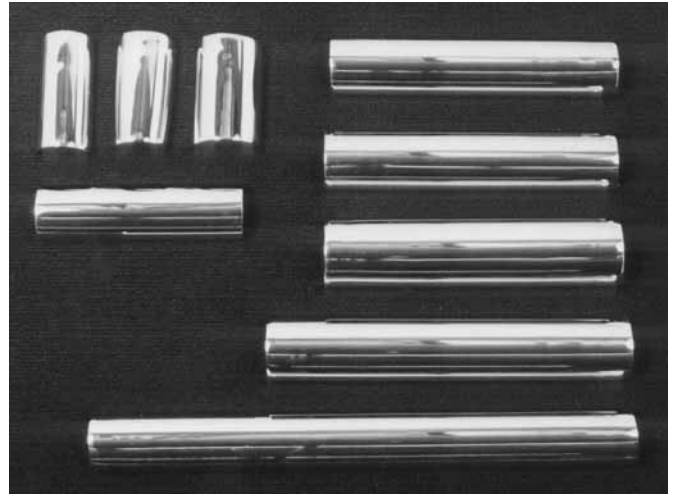

Chrome Universal Straight Heat Shields

Heat shields include mounting clamps and are available for 1 3/4" or 2 1/4" pipes. Sold each.



Six Gun Pipe End Set

Tips fit pipes with full coverage heat shields over 1-3/4" pipes.

PCP Fits O.D.

59877 2-1/4"
27243 1-3/4"

For 2 1/4" Pipes

45206 4" heat shield
45209 10" heat shield

For 1 3/4" Pipes

94012 10" heat shield
94013 12" heat shield
94014 18" heat shield



Chrome Billet Aluminum Custom End Caps

Fits all 2.25" pipes.
73562



2 Stage Torque Baffle Set

4 Piece set allows variation of air flow for 2-1/4" pipes.
59597



2-3/8" Torque Tube Set

Features improved baffling and back pressure for FX, XL and FXD Screamin' Eagle muffler sets.
27538

Heat Shields

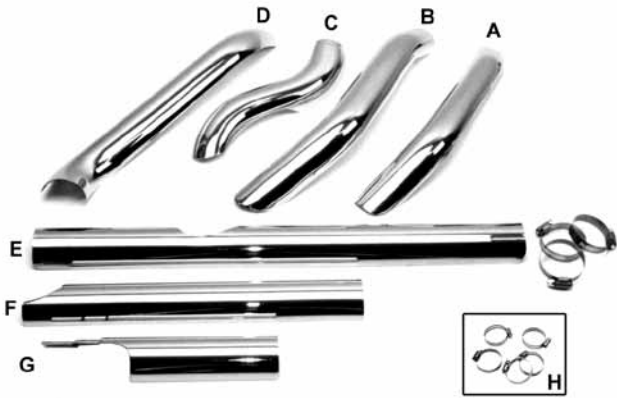

Chrome FLT Stock Heat Shields for 1983-on PCP

PCP	Application
45147	(A) 1983-97 Front head pipe (65630-83C)
45148	(B) 1984-97 Rear head pipe (65632-83C)
45159	(C) 1983-on Left top (65647-83)
45216	(D) 1985-94 Left rear (65636-85)
94010	(E) 1981-91 Lower (22 1/2") (65634-81C)
45149	(F) 1992-97 Low right (65634-92)
45936	(G) 1992-94 Low right rear (65611-92)
16281	(H) 1984-99 Clamp, (shield) (9955) (ea)



Sportster Exhaust Pipe Heat Shields 1986-03

Chrome covers for Stock or Drag pipes.

94025	Set	Drag/Custom pipes
94027	Set	Cycle Shack drag/muffler
45160	Front	Cycle Shack shot gun pipe 1990-99



Softail 1986-99 Muffler/Drag Pipe Heat Shields

Designed to fit with either Drag or Muffler type pipes. Covers do not have cut out for cross-over tube. Sold in sets.

94020	Smooth
94021	Perforated
94024	Ribbed

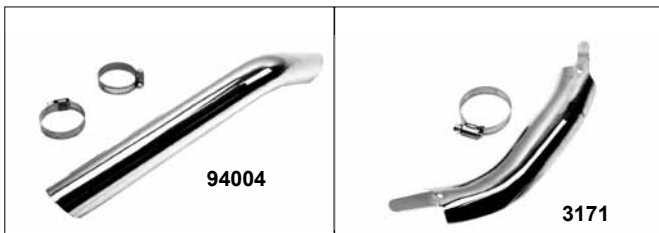

Chrome Heat Shields

3171	Front FLT 1981-88
94004	FXR equalizer 1983-on, FXST 1986-99

Universal Heat Shields

Fits 1-1/2" to 2-5/16" Pipes and includes clamps for installation. Sold each.

PCP	Length	Type
3760	9"	Perforated
45153	8"	Flame
45244	9"	Flame
45154	11-1/2"	Flame

Heat Shields



Exhaust Gasket Set BT 1985-on & XL 1986-on
Includes 2 snap rings.
25607



XL Heat Shields 1986-03
94025 Set for 1-3/4" drag pipes



Mesh Exhaust Port Gasket BT 84-on, XL 86-on
25608 5 Pack



Heat Shield for 1-3/4" Pipes
Fits the lower part of the front pipe on FL crossover dual or 2-into-1 exhaust systems for Softail® models.
94011 10" Long with notch
1164 7" long



Chrome Front Muffler Pipe Junction Shield
PCP Application
45556 XL 1984-03



Chrome 2:1 Shield Set
Fits PCP #95802 1986-99 FLST exhaust.
45562

Exhaust Hardware



Exhaust Port Fasteners

The bolt holds the pipe secure, not merely by thread tension, but clamps the pipe to the head by wedging the patterned washers against the pipe while the washers are, in turn, wedged between the pipe and the "E" clip locks fitted to the bolt heads.

2017 Evolution Big Twin motors 1984-99



Evo Exhaust Flange Kit

Each kit includes: 2 chrome exhaust flanges, retaining rings, exhaust gaskets and chrome acorn nuts and washers.

27202 Softail 84-03, FXD 91-05, FLT 84-on, XL 86-01
FXR 84-94



Genuine James Exhaust Gaskets.

PCP Description

79467 Pipe to head 1984-91 BT & XL Evo (65324-83) (10)

79468 Pipe to head 1992-on BT & XL (65324-83-A) (5)

79469 Muffler clamp 1985-94 all FLT (65721-85) (10 pk)

79470 Inter connect 1982-94 XL, FXR (65781-82) (ea)

79472 Inter connect 1991-02 Dyna (65826-90) (ea)



Stainless Steel Taper Valve Exhaust Kit

This valve fits into the header at the flange area to compensate for exhaust velocity when large diameter pipes are installed. Fits Evo and XL models 1986-on with large O.D. aftermarket pipes. Kit includes 2 valves with gaskets. Fits Softail 84-on, FXD 91-on, FXR 84-94, XL 86-on

27502 Kit



James Evo Exhaust Nut Kit

Includes 4 chrome acorn nuts, 4 washers, and 2 mesh gaskets, for 1984-03 BT models.

79833



Colony Exhaust Stud and Nut Kit

Fits Evo, Twin Cam models.

72188

EVO Exhaust Port Gasket

Stainless outer body and "Crush" fibre inner body

25225 Sold in 10 packs.



Exhaust Stud Kit

Includes 4 studs and 4 stainless flanged nuts. Fits XL 1986-on and BT 1984-96.

24071

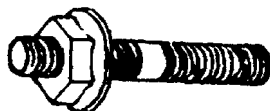

Jims Exhaust Stud Drill Fixture

Fits BT and XL 1984-on exhaust ports to align for the drilling of a broken exhaust stud.

31524

